



# OFFICE MEISTER™

## SERIES

# 125LBS



### FEATURES

**KINGPIN:** 7/16" Rivet  
**RACEWAY:** 7/32" Diameter upper and lower race; hardened steel load bearings  
**BEARING:** Precision ball bearing  
**AXLE&NUT:** 1/4" Riveted axle  
**FINISH:** Black Ionic finish

**HARDENED:** Yoke and washers  
**SPECIAL:** Upper and lower diameter race is equal for added performance and strength  
**LEG SPACING:** 1"

### EXCELLENT FOR:

- Seating
- Office furniture
- IV Poles
- Medical equipment
- Institutional equipment
- Store fixtures



### OPTIONS:

AN Axle and Nut

### FINISHES:

10241 Black Ionic  
 1022 Chrome

Inquiries on other finishes welcome

BIFMA approved

WHEEL		CASTER				PART NUMBER		
Diameter	Tread Width	Capacity Lbs.	Bearing Type	Swivel Radius	Overall Height	Wheel Type	Swivel	Caster Weight (lbs)
3"	7/8"	75 125	Precision Precision	3 1/8"	4 3/32"	ProTech™ Black Crown - PB PurThane™	SOM341-***-PROBL-PB-TG SOM341-***-PTN-PB-TG*	0.80 1.02

\*350 ANSI/BIFMA X5.1 - 2017

\*\*\* Caster weight and OH based on Plate

\*\*\* See stem options for overall height (OH) differences

### THREADED STEMS HEX WASHER

-.0937" [2.38mm] To Std OH

***	DIAMETER	LENGTH	TYPE
3/8-16X1HW	3/8"	1"	NC
1/2-13X1HW	1/2"	1"	NC
1/2-13X1 1/2HW	1/2"	1 1/2"	NC
1/2-13X2 1/4HW	1/2"	2 1/4"	NC



### THREADED STEMS HEX NUT

+.1562" [3.97mm] To Std OH

***	DIAMETER	LENGTH	TYPE
1/2-13X1HN	1/2"	1"	NC
1/2-13X1 7/8HN	1/2"	1 7/8"	NC
1/2-13X3 1/2HN	1/2"	3 1/2"	NC



### PLATE DIAGRAMS

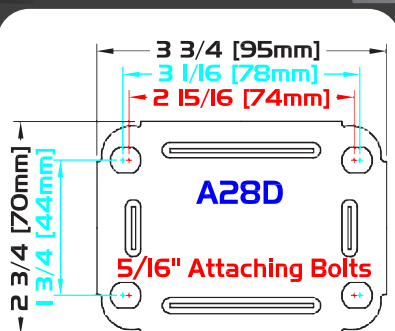

STANDARD PLATE: A28D

Plate Thickness: 3/32"

### ROUND STEMS

-.0937" [2.38mm] To Std OH

***	DIAMETER	LENGTH	TYPE
437X1 7/8	7/16"	1 7/8"	Plain
437SX1	7/16"	1"	Friction Ring
437SX1 5/16	7/16"	1 5/16"	Friction Ring
437SX1 7/8	7/16"	1 7/8"	Friction Ring

